

TANK-820-H61

■ Intel® Sandy Bridge 3-Slot Embedded System

Features

- 2nd/3rd generation Intel® Core™ low power desktop processors (max TDP. 65W)
- On-board 2GB DDR3 memory and one DDR3 SO-DIMM slot (system max. 10GB)
- Dual wide range DC power support



Versatile Expansion Interface

The TANK-820 series has various kinds of expansion interfaces which allow you to connect additional circuits or expansion boards to the system via IEI riser cards. These expansion options provide flexible function enhancement and simplify system integration.

- The two types of backplane support standard PCI/PCIe cards with maximum dimensions (111 mm in width x 190 mm in length).
- The rated voltage and current of the backplane

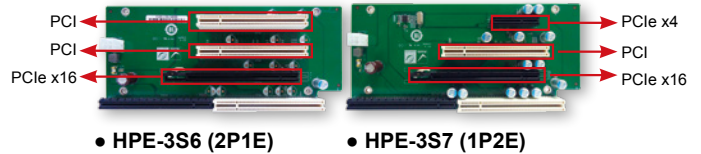

Voltage	Current	Voltage	Current
+5 V	7 A	-12 V	0.1 A
+12 V	3.75 A	+3.3 V	8 A

Max. power supported by the backplane: <45W

Backplane	Slot	TANK-800	TANK-820
		Signal	Signal
HPE-3S6 (2P1E)	PCI	PCI	PCI
	PCIe x16	PCIe x4	PCIe x8
HPE-3S7 (1P2E)	PCI	PCI	PCI
	PCIe x4	PCIe x1	PCIe x1
	PCIe x16	PCIe x2	PCIe x8

The system default power is 90 W. **The maximum total power of the backplane to support expansion cards is 45 W.** The power of the selected expansion cards can not exceed the max. power (45 W), otherwise, the system may be unstable.

Fully Integrated I/O

Front I/O

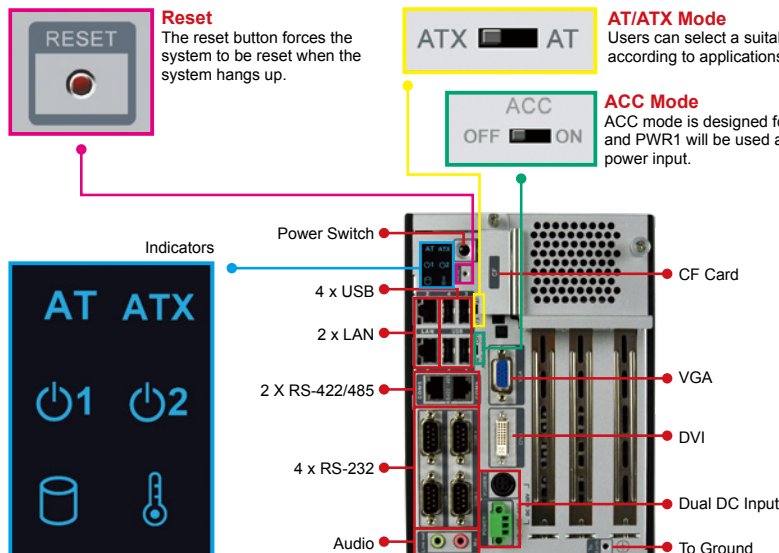

Rear I/O

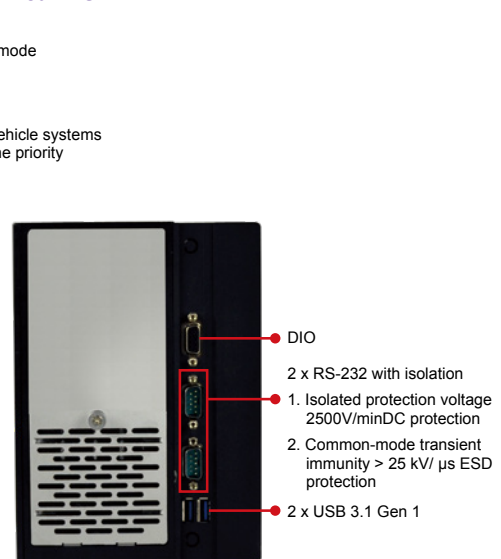

Specifications

Model Name		TANK-820-H61
Chassis	Color	Black C + Silver
	Dimensions (WxDxH) (mm)	133 x 269 x 208
	System Fan	Fanless
	Chassis Construction	Extruded aluminum alloys
Motherboard	CPU	Intel® Core™ i5-2xxT (above 2.7 GHz) Intel® Core™ i3-2xxT (above 2.5 GHz) Intel® Pentium® G6xxT (above 2.2 GHz)
	Chipset	Intel® H61
	System Memory	On-board DDR3 2 GB memory 1 x 204-pin DDR3 SO-DIMM (system max: 10 GB)
Storage	Hard Drive	1 x 2.5" SATA 3Gb/s HDD/SSD bay
	CF Card/CFast	1 x CF Type II
I/O Interfaces	USB 3.1 Gen 1 (5Gb/s)	2
	USB 2.0	4
	Ethernet	2 x RJ-45 PCIe GbE by Realtek 8111E controller
	COM Port	6 x RS-232 (DB-9, two with isolation) 2 x RS-422/485 (RJ-45)
	Digital I/O	8-bit digital I/O, 4-bit input/4-bit output
	Display	1 x VGA, 1 x DVI-I
	Resolution	VGA: Up to 2048 x 1536@75Hz DVI-I: Up to 1920 x 1080@60Hz
	Audio	1 x Line-out, 1 x Mic-in
	Expansions	PCI
PCIe		2P1E: One PCIe x8 (physical PCIe x16 slot) 1P2E: One PCIe x1 (physical x4 slot), One PCIe x8 (physical x16 slot)
Power	Power Input	DC Jack: 9 V~24 V DC Terminal Block: 9 V~24 V DC
	Power Consumption	19 V@3.5 A (Intel® Core™ i3-2100 with 6 GB DDR3 memory) w/o add-on card
Reliability	Mounting	Wall mount
	Operating Temperature	-20°C ~ 60°C with air flow (SSD), 5% ~ 95%, non-condensing
	Storage Temperature	-20°C ~ 70°C
	Operating Shock	Half-sine wave shock 5G, 11ms, 3 shocks per axis
	Operating Vibration	MIL-STD-810F 514.5C-2 (with SSD)
	Weight (Net/Gross)	4.2 kg/6.3 kg
OS	Safety/EMC	CE/FCC
	Supported OS	Microsoft® Windows® Embedded Standard 7 E, Microsoft® Windows® XP Embedded

Dimensions (Unit: mm)

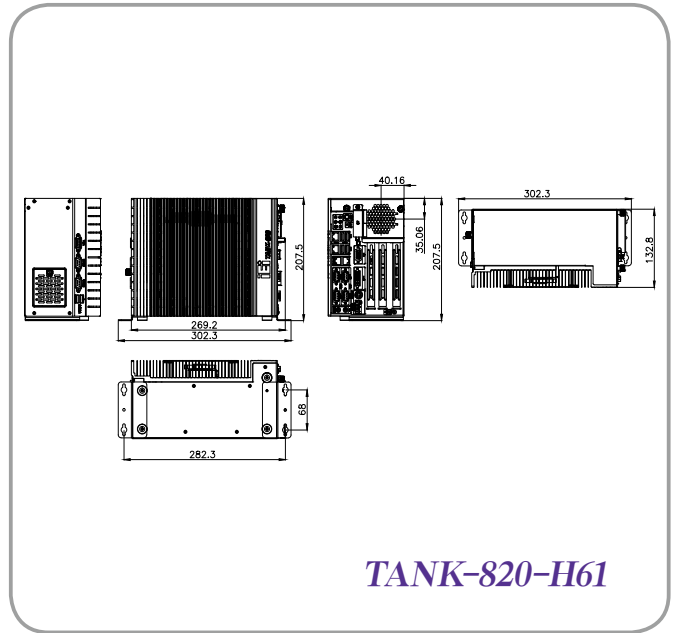

Ordering Information

Part No.	Description
TANK-820-H61-i5/2G/2P1E-R22	Fanless wide temperature embedded system with one PCIe x8 and two PCI expansions, Intel® Core™ i5 dual-core 2xxT CPU (above 2.7 GHz, TDP 35 W), dual 9 V-24 V DC-IN, 2 GB DDR3 on-board memory, -20°C ~ 60°C
TANK-820-H61-i5/2G/1P2E-R22	Fanless wide temperature embedded system with one PCIe x1, one PCIe x8 and one PCI expansion, Intel® Core™ i5 dual-core 2xxT CPU (above 2.7 GHz, TDP 35 W), dual 9 V-24 V DC-IN, 2 GB DDR3 on-board memory, -20°C ~ 60°C
TANK-820-H61-i3/2G/2P1E-R22	Fanless wide temperature embedded system with one PCIe x8 and two PCI expansions, Intel® Core™ i3 dual-core 2xxT CPU (above 2.5 GHz, TDP 35 W), dual 9 V-24 V DC-IN, 2 GB DDR3 on-board memory, -20°C ~ 60°C
TANK-820-H61-i3/2G/1P2E-R22	Fanless wide temperature embedded system with one PCIe x1, one PCIe x8 and one PCI expansion, Intel® Core™ i3 dual-core 2xxT CPU (above 2.5 GHz, TDP 35 W), dual 9 V-24 V DC-IN, 2 GB DDR3 on-board memory, -20°C ~ 60°C
TANK-820-H61-P/2G/2P1E-R22	Fanless wide temperature embedded system with one PCIe x8 and two PCI expansions, Intel® Pentium® dual-core G6xxT CPU (above 2.2 GHz, TDP 35 W), dual 9 V-24 V DC-IN, 2 GB DDR3 on-board memory, -20°C ~ 60°C
TANK-820-H61-P/2G/1P2E-R22	Fanless wide temperature embedded system with one PCIe x1, one PCIe x8 and one PCI expansion, Intel® Pentium® dual-core G6xxT CPU (above 2.2 GHz, TDP 35 W), dual 9 V-24 V DC-IN, 2 GB DDR3 on-board memory, -20°C ~ 60°C

Options

Item	Part No.	Description
OS: XP	TANKCF-800-D525-XPE-4G-R10	OS Image with XPE, For TANK-800 D525 Series, W/Compact Flash Memory Card 4GB, R10
OS: Windows Embedded 7 (4GB CF Card)	TANKCF-800-D525-WES7E-4G-R10	OS Image with Windows® Embedded Standard 7 E for TANK-800 D525 Series, 4 GB CompactFlash® card, RoHS
System Fan	EMB-FAN-KIT02-R10	Fan Module; MODIFY 31100-000272-RS; +12V DC; 4PIN; 40*40*15mm ; STANDARD;; FD124015LB2W3;; L= 400mm MOLEX 5051-04P P=2.54; CCL; RoHS

Packing List

1 x Power Cord	4 x HDD Screw	1 x Pluggable DC-in Terminal Block
1 x Power Adapter	4 x Rubber Foot Pad Screw	2 x Mounting Bracket
2 x Foot Pad	4 x Mounting Bracket Screw	2 x RJ-45 to DB-9 COM Port Cable
4 x Fan screw		