



Features

- 10.1" New Generation Stainless Steel Panel PC
- Freescale i.MX6 DualLite 1.0GHz Onboard Processor
- True Flat Front Bezel Design and Grade 304 Stainless Steel Enclosure (Grade 316 for Option)
- IP66/IP69K Rated with M12 Connectors
- Support Resistive Touch, Projected Capacitive Touch, and Glass
- Touch on/off Button on the Side Edge for Hygienic Cleaning
- Support Ergonomic Versatile Mounting: Yoke Mounting / Space-saving VESA 75 x 75 mm Mounting

Specifications

System		
CPU	Freescale i.MX6 Dual Lite, ARM Cortex A9(2x Cores, 1.0GHz)	
System Chipset	SoC	
Memory	Onboard 1GB DDR3 SDRAM	
IO Port		
USB	1 x M12 8-pin for 2 x USB 2.0 with waterproof cover and chain	
Serial / Parallel	1 x M12 8-pin COM1, RS-232/422/485, default RS-232, with waterproof cover and chain	
LAN	1 x M12 8-pin for LAN with waterproof cover and chain (POE for option)	
Others	1 x Touch on/off button on the side	
Power Connector	1 x M12 3-pin for DC power with waterproof cover and chain 1 x Power switch on the side	
Option	2 x M12 blank for option 1 x CAN 1 x PoE	
Storage Space		
HDD	Onboard 4GB eMMC NAND Flash	
Expansion		
Expansion Slot	1 x miniPCIe slot for WIFI/BT(optional), 4G/LTE(optional)	
RFID module	RFID module design on the front side(optional)	
Display		
Display Type	Standard	High Brightness Optional
Display Type	10.1" TFT-LCD	10.1" TFT-LCD
Max. Resolution	1280 x 800	1280 x 800
Max. Color	16.7M	16.7M
Luminance (cd/m ²)	350	1000
View Angle	170(H) /170(V)	170(H) /170(V)
Contrast	800:1	800:1
Backlight Lifetime	50,000 hrs	50,000 hrs
Touch Screen		
Type	Resistive Touch (For R model) Projected Capacitive Touch (For P model) Glass (For G model)	
Interface	SPI(Resistive Touch) / USB(Projected Capacitive Touch)	
Light Transmission(%)	Resistive Touch : 80% / Projected Capacitive : 90%	
Power		
Power Input	DC 9~36V	
Power Consumption	ViTAM-610P: 10W	

Dimensions

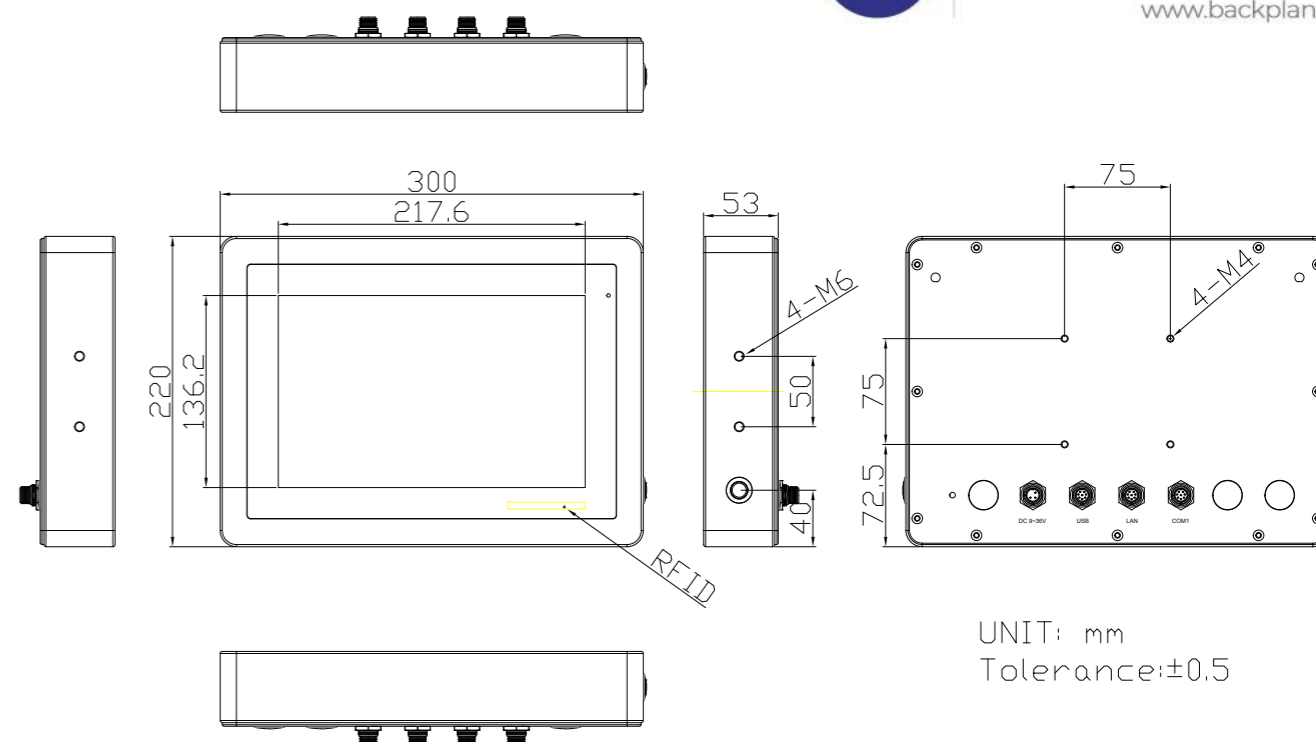

UNIT: mm
Tolerance:±0.5

Mechanical	
Construction	304 Stainless steel chassis(default), 316 Stainless steel chassis(optional)
Mounting	VESA mount 75 x 75, Yoke mount (optional)
IP Rating	Total IP66/IP69K
Dimensions	300 x 220 x 53 mm
Net Weight	3.8 kg
Environmental	
Operating Temperature	0~50°C
Storage Temperature	-30~70°C
Storage Humidity	10 to 90% @ 40°C, non- condensing
Certificate	CE/FCC Class A
Operating System Support	
Android 6.0.1 / Linux 4.1.15	
Ordering Information	
ViTAM-610P	10.1" WXGA IP66/IP69K stainless steel panel pc, Freescale i.MX6 Dual Lite ARM Cortex A9, 1GB DDR3 RAM, 4GB eMMC, projected capacitive touch, 9~36V DC power input with Adapter
ViTAM-610R	10.1" WXGA IP66/IP69K stainless steel panel panel pc, Freescale i.MX6 Dual Lite ARM Cortex A9, 1GB DDR3 RAM, 4GB eMMC, 5 wire resistive touch window, 9~36V DC power input with Adapter
ViTAM-610G	10.1" WXGA IP66/IP69K stainless steel panel pc, Freescale i.MX6 Dual Lite ARM Cortex A9, 1GB DDR3 RAM, 4GB eMMC, protection glass, 9~36V DC power input with Adapter
ViTAM-610PH	10.1" WXGA IP66/IP69K stainless steel panel pc, Freescale i.MX6 Dual Lite ARM Cortex A9, 1GB DDR3 RAM, 4GB eMMC, projected capacitive touch, 9~36V DC power input with Adapter, 1,000 nits LCD
ViTAM-610RH	10.1" WXGA IP66/IP69K stainless steel panel panel pc, Freescale i.MX6 Dual Lite ARM Cortex A9, 1GB DDR3 RAM, 4GB eMMC, 5 wire resistive touch window, 9~36V DC power input with Adapter, 1,000 nits LCD
ViTAM-610GH	10.1" WXGA IP66/IP69K stainless steel panel pc, Freescale i.MX6 Dual Lite ARM Cortex A9, 1GB DDR3 RAM, 4GB eMMC, protection glass, 9~36V DC power input with Adapter, 1,000 nits LCD



Backplane Systems Technology Pty Ltd
TEL 02 9457 6400
sales@backplane.com.au
www.backplane.com.au