



Features

- 17" Industrial Compact Size Panel PC
- Flat front panel touch screen
- Fanless design
- Intel Atom D2550 1.86GHz CPU built-in
- Onboard 4GB DDR III 800 MHz
- 9~36VDC wide-ranging power input
- IP65 compliant front panel
- Optional projected capacitive touchscreen support 7H anti-scratch surface

Specifications

System	
CPU	Onboard Intel Atom Cedar View D2550 1.86GHz Dual Core Processors
System Chipset	Intel NM10 Express Chipset
System Memory	Onboard 4GB DDR III 800 MHz
IO Port	
USB	2 x USB 2.0 type A
Serial/Parallel	1 x RS-232 DB-9 1 x DB-9 RS-232/422/485 (Default RS-232)
Audio	1 x Audio Line Out
LAN	2 x GbE RJ-45
Power	1 x 3-pin DC Power input terminal 1 x 2-pin power switch
LED light	1 x Power LED Light
Option	2 x RS-232 DB-9 + 1 x Mini-PCIe slot via TB-528C2ME1 2 x CAN bus via TB-528CAN2 2 x USB 2.0 type A + 1xRS-232 DB-9 + 1 x Power button via TB-528C1U2P1 2 x USB 2.0 type A + via TB-528U2
Storage Space	
HDD	1 x 2.5" SATA HDD bay for SATA HDD (Easy Accessible)
Movable device	1 x SD card slot, up to 32GB
Display	
Display Type	17" TFT-LCD
Max. Resolution	1280 x 1024
Max. Color	16.2M
Luminance (cd/m ²)	350
Contrast Ratio	1000:1
View angle(H°/V°)	H:170° / V:160°
Backlight Lifetime	30,000 (hrs)
Touch screen	
Type	Resistive Touch / Projected Capacitive Touch (for P model)
Interface	USB
Light Transmission(%)	80% / 90% (for P model)
Expansion	
Expansion Slot	1 x Internal Mini-PCIe half size

Dimensions

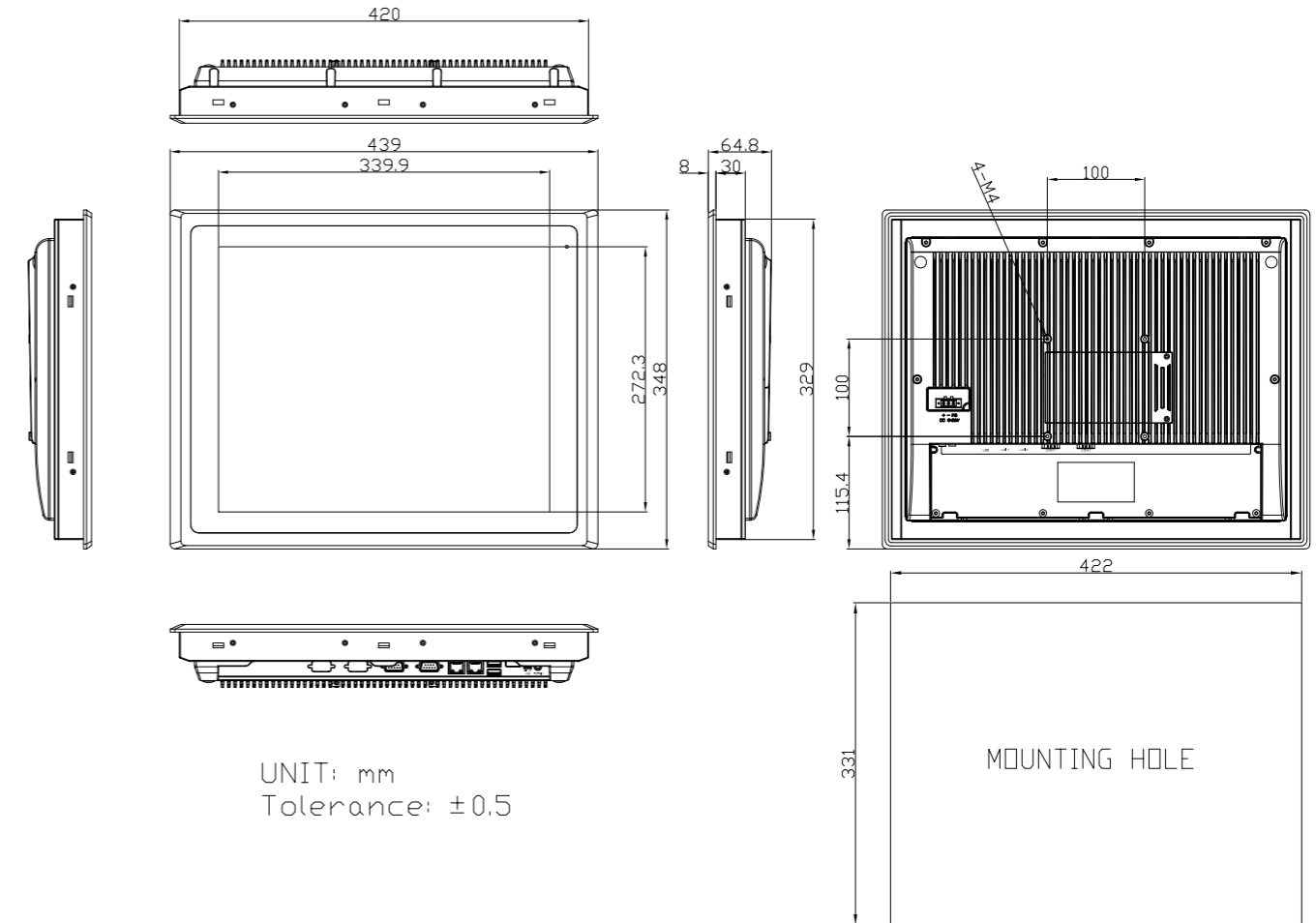

Power	
Power Input	9~36V DC
Power Consumption	34.7 W

Mechanical	
Construction	Sliver aluminum front bezel and chassis
IP Rating	IP65 front panel
Mounting	Panel mounting, VESA 100 x 100
Dimensions (WxHxD)	439mm x 348mm x 64.8mm
Net Weight (Kgs)	5.1

Environmental	
Operating Temperature	0~50°C
Storage Temperature	-20~60°C
Storage Humidity	10 to 90%@ 40°C, non-condensing
Certificate	CE / FCC Class A / UL

Operating System Support	
Operating System	Windows 32-bit XP Pro, Windows 7 32-bit, Windows CE 6.0, Fedora 14



Backplane Systems
Technology Pty Ltd
TEL 02 9457 6400
sales@backplane.com.au
www.backplane.com.au