

Features

- 10.1" Food Industrial Panel PC
- Flat front panel touch screen
- Fanless design
- Intel Celeron N2930 Processor
- Onboard 4GB DDR 3L 1600 MHz
- Wide range DC 9~36V power input

Specifications

System	
CPU	Onboard Intel Celeron N2930 Processor (2M Cache, 1.83GHz)
System Chipset	SoC
Memory	Onboard 4GB DDR3L SDRAM

IO Port	
USB	2 x USB 3.0 type A
Serial / Parallel	1 x RS-232/422/485 DB-9, default RS-232(COM1) 1 x RS-232 DB-9(COM2)
LAN	2 x GbE LAN RJ-45
Audio	1 x Line Out
Power	1 x 3-pin DC Power input terminal 1 x 2-pin connector for power on/off button

Storage Space	
HDD/SSD	1 x 2.5" SATA HDD space (Easily Accessible)
Others	1 x internal SD slot onboard

Expansion	
Expansion Slot	1 x Internal Mini-PCIe slot full size on board

Display	Standard	High Brightness Optional
Display Type	10.1" TFT-LCD	10.1" TFT-LCD
Max. Resolution	1280 x 800	1280 x 800
Max. Color	16.7M	16.7M
Luminance (cd/m ²)	350	1000
View Angle	170(H) /170(V)	170(H) /170(V)
Contrast	800:1	1000:1
Backlight Lifetime	25,000 hrs	50,000 hrs

Touch Screen	
Type	Projected Capacitive Touch (For P model) Glass (For G model)
Interface	USB
Light Transmission(%)	Over 90%

Power	
Power Input	DC 9~36V
Power Consumption	FABS-810P: 14W

Dimensions

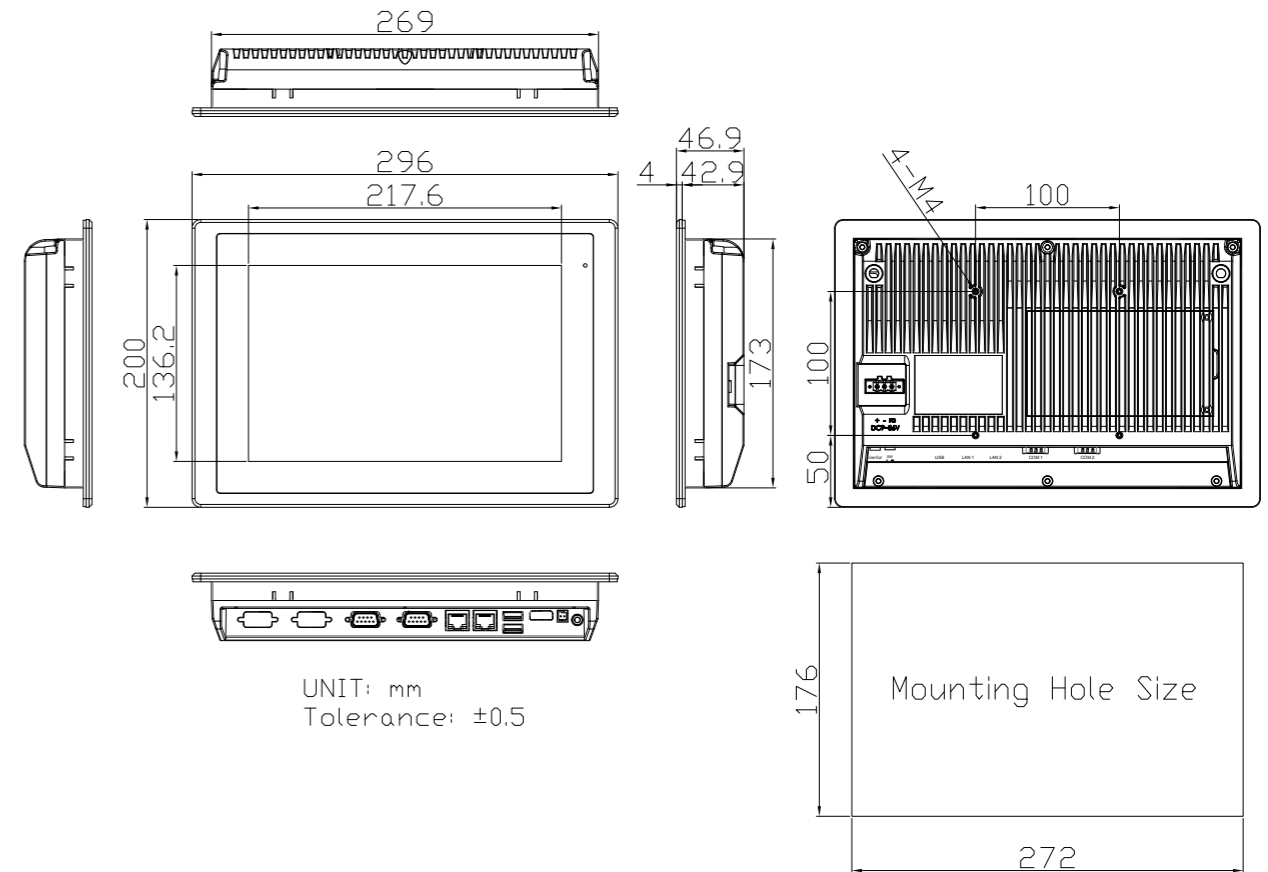

Mechanical	
Construction	304 Stainless steel front bezel (Default) 316 Stainless steel front bezel (Optional) Aluminum back cover
Mounting	Panel mount, VESA mount 100 x 100
IP Rating	Front Panel IP66/IP69K
Dimensions	296 x 200 x 47 mm
Net Weight	1.9 kg

Environmental	
Operating Temperature	0~50°C, -20~60°C (option)
Storage Temperature	-20~60°C
Storage Humidity	10 to 90% @ 40°C, non- condensing
Certificate	CE / FCC Class A/EN 1672-2

Operating System Support	
WEC 7, Windows Embedded 7, Windows Embedded 8.1, Windows 10 IoT ENT LTSB	

Ordering Information	
FABS-810P (Barebone)	10.1" WXGA fanless HMI barebone with Celeron N2930(1.83.GHz) CPU, 4GB DDR3L RAM, Projected Capacitive touch,, 9~36VDC input with adapter, Stainless front bezel and Aluminum chassis.
FABS-810G (Barebone)	10.1" WXGA fanless HMI barebone with Celeron N2930 (1.83.GHz) CPU, 4GB DDR3L RAM, Protection Glass, 9~36V DC input with adapter, Stainless front bezel and Aluminum chassis.



Backplane Systems Technology

Backplane Systems Technology Pty Ltd

TEL 02 9457 6400
sales@backplane.com.au
www.backplane.com.au