

R19IK7T-POM1

19" Panel PC (Intel 7th Generation Core i3/i5/i7 Processor)

Mechanical Design

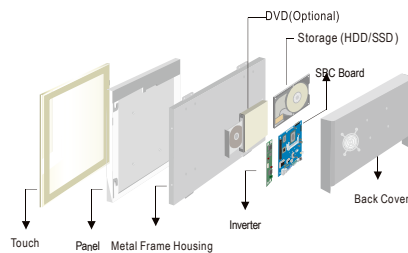

Mechanical design

Features:

- 19" 1280 x 1024 Resolution
- Intel 7th Generation Core i3/i5/i7 processor (Kabylake)
- Flexible storage devices, one 2.5-inch HDD and one SSD
- Multiple I/Os, Two Serial Ports and Four USB 3.0 Ports
- 12V DC Power input
- DP Support 4096x2304@60Hz
- HDMI Support 4096x2304@24Hz

Open Frame

Dimensions

Fully Integrated I/O

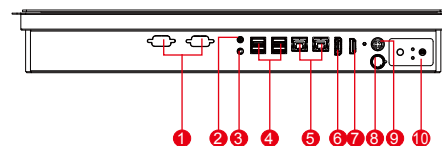
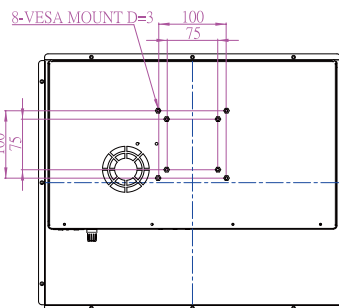
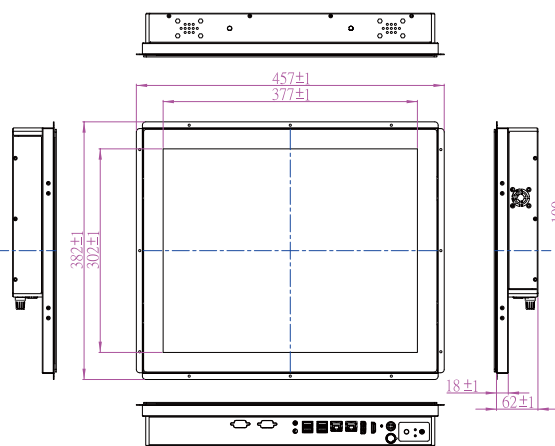

1. 2 x RS-232/422/485
2. Mic In
3. Line Out
4. 4 x USB 3.0
5. LAN(10/100/1000 Mbps)
6. DP 1.2
7. HDMI 1.4
8. Dimming Knob
9. 12V DC in
10. OSD Membrane

- * Measurements shown in mm
- * Tolerance of all dimensions is shown as follow 0~30 mm ± 0.1 mm,
- * 30~50 mm ± 0.15 mm, 50~120 mm ± 0.2 mm, above 120 mm ± 0.25 mm
- * Note: this is a simplified drawing and some components are not marked in detail. Please contact our sales representative if you need further product information.

Specifications

System Specifications

- CPU : Intel® Core™ i7-7700T Processor, 2.9 GHz
Intel® Core™ i5-7500T Processor, 2.7 GHz
Intel® Core™ i3-7100T Processor, 3.4 GHz
- System Chipset : Intel® H170
- System Memory : 1 x SO-DIMM, Max 16GB DDR4 2400 MHz default 4GB
- Storage : 1 x M.2 SSD, Max 512GB
1 x 2.5" 500GB HDD (default)
- Audio : Realtek HD Audio Codec
- Network : Intel® Ethernet Controller I211-AT + Intel® Gigabit Ethernet PHY I219-LM

Input / Output

- Serial Ports : 2 x RS232/422/485(default RS232)
- USB Ports : 4 x USB 3.0
- Ethernets : 2 x RJ45-10/100/1000 Mbps
- DP Port : 1 x DP 1.2
- HDMI Port : 1 x HDMI 1.4
- Audio : Line-Out, Mic in

Power Management

- Power Input : 12V DC IN (Lockable Power Jack)
- Power Consumption : 90W (typ.)(Max.backlight & high CPU load)

Accessories

- External Adapter : 110~240V Ac-in Power Adapter

Display Specifications

- Size/Type : 19" TFT
- Resolution : 1280x1024
- Contrast Ratio : 1000:1 (typ.)
- Brightness : 250 nits
- Viewing Angles : -85~85 (H); -80~80 (V)
- Max Colors : 16.7M

Environment

- Operating Temperature : 0 °C to 50 °C
- Operating Humidity : 10% to 90% (non condensing)

Security Support

- Trusted Platform Module (TPM 2.0)

Order Options

Mechanical : Open Frame	Storage : 2.5"HDD/2.5" SSD/ M.2 SSD
Touch : P-CAP	RAM : DDR4 2400 Max 16GB
	OS : Windows 10 IoT Enterprise

Expansion Slot

- 2 x M.2(1 for WiFi, 1 for SSD), 1 x PCIe x 16(Optional)

*Customized housing required if you need to have the PCIe expansion