

W24IK3S-SPA269-P, 23.8-inch Stainless P-Series Panel PC

Stainless IP69K with Waterproof Conduit Solutions

Winmate provides 23.8-inch IP69K Stainless Steel Panel PC with the high performance Intel Core i5-7200U Kaby Lake processor and a waterproof conduit pipe for added cable protection. The IP69K series is built to withstand extensive wash downs with corrosion resistance against cleaning agents, especially against close-range high-pressure, high temperature wash downs. The level of protection allows for easy cleaning and sterilization using water with temperatures of up to 80°C and pressure of up to 30 Bar. A custom-built waterproof conduit pipe was also provided for the customer with a cover plate, allowing for an additional layer of protection for the panel pc cables.



* Yoke mount Stand kit is an option. accessory.

Highlights

- Intel® Core™ i5-7200U, 2.50 GHz
- Fanless cooling system
- SUS304 stainless steel for food and chemical industries
- Full IP69K waterproof enclosure, good corrosion resistance
- A true flat, easy-to-clean front surface with edge-to-edge design
- Waterproof sealed conduit pipe for cable protection
- Supports VESA mount, Panel mount and optional Yoke mount stand

W24IK3S-SPA269-P, 23.8-inch Stainless P-Series Panel PC

Stainless IP69K with Waterproof Conduit Solutions

Display Specification

| | |
|----------------|---|
| Size | 23.8" |
| Resolution | 1920 x 1080 |
| Contrast Ratio | 3000:1 |
| Brightness | 250 nits |
| Viewing Angle | -89~89 (H); -89~89(V) |
| Max Colors | 16.7M |
| Touch | Projected Capacitive Multi-Touch (P-CAP) Anti-glare coating (Optional) |

System Specifications

| | |
|------------------|---|
| CPU | Intel® Core i5-7200U 2.5GHz |
| System Chipset | Intel® SoC Integrated |
| System Memory | 4GB DDR4 2133 (Optional up to 16GB) |
| Storage | 64GB B-key M.2 2242 (Optional up to 512GB) |
| BIOS | Insyde BIOS |
| Audio | Realtek HD Audio Codec |
| LAN Chip | Intel® Gigabit-LAN Controller I211AT + PHY I219LM |
| Operating System | Windows 10 IoT Enterprise (Optional) Ubuntu 18.04 (Optional) |

Interface

| | |
|--------------|----------------------------|
| Ethernet | 2 x RJ 45-10/100/1000 Mbps |
| Serial Ports | 1 x RS-232/422/485 |
| USB Ports | 2 x USB 3.0 |
| Power Input | 1 x 2.5 DC jack |
| HDMI | 1 x HDMI 1.4 output |

Security Function

| | |
|----------|---------|
| Security | TPM 2.0 |
|----------|---------|

Keyboard and Input

| | |
|------------------|---------------|
| Physical Buttons | Power & Reset |
| LED Indicators | Power & HDD |
| Touch | P-Cap |

Power Management

| | |
|-------------------|--|
| Power Input | 12V DC input with AC to DC Adapter Optional 9~36V DC input with 3 pin phoenix connector |
| Power Consumption | 62W (typ.) (Max. backlight and high CPU load) |
| AC Adapter | 100~240V AC to 12V DC Adapter |

Mechanical Specifications

| | |
|----------------|---|
| Dimensions | 600 x 369 x 56mm |
| Cutout | 582 x 351mm |
| Cooling System | Fanless design |
| Housing | Stainless steel |
| Mounting | VESA Mount (100x100mm), Panel mount, optional Yoke mount stand |

Environment

| | |
|-----------------------|-----------------------------|
| Operating Temperature | 0 °C to 45 °C |
| Storage Temperature | -10 °C to 60 °C |
| Operating Humidity | 10% to 95% (non condensing) |
| IP Rating | IP69K |

Standards and Certification

| | |
|-----|---------|
| EMC | CE, FCC |
|-----|---------|

Accessories

- 1 x Waterproof Conduit 1.5m
- 1 x Elbow for connect the conduit
- 1 x AC to DC power adapter with power cord
- Yoke mount stand kit (Optional)
- Open wire cable for phoenix connector (Default for 9~36V DC input sku)

Drawing

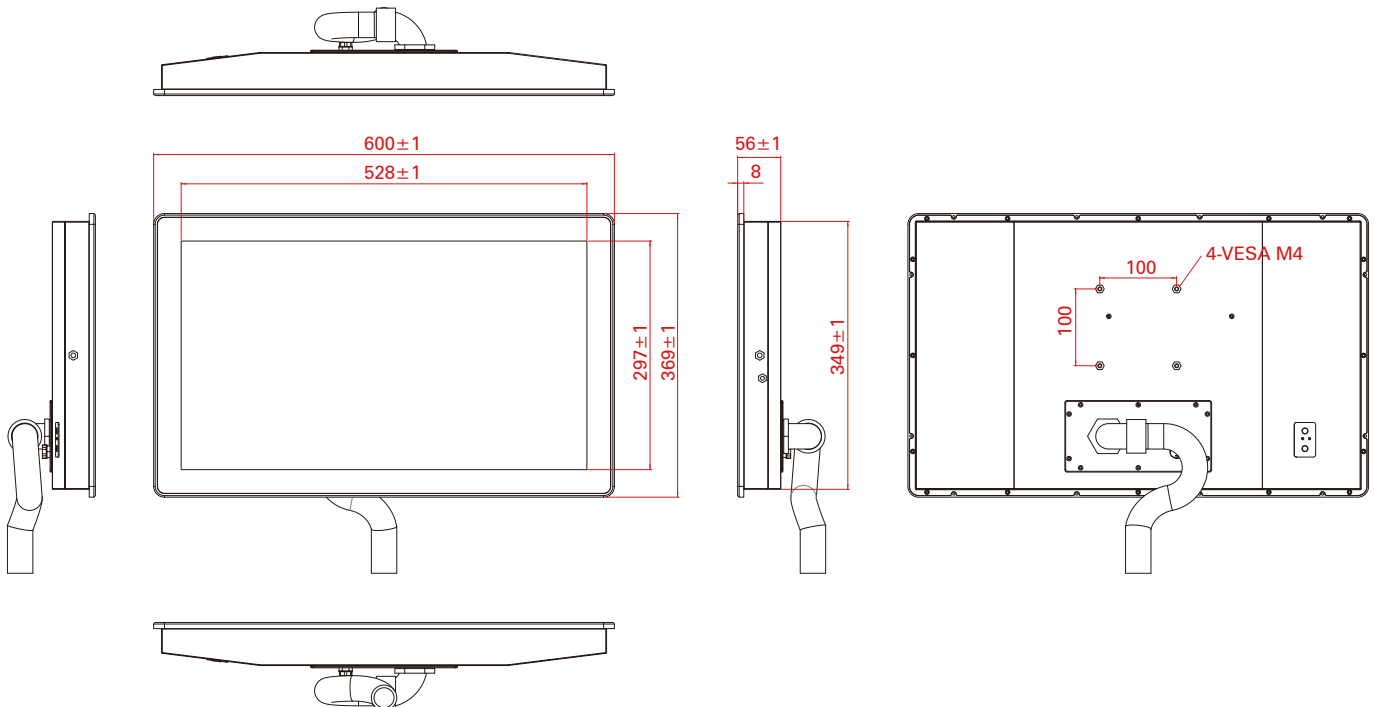

* Yoke mount Stand kit is an option. accessory.

W24IK3S-SPA269-P, 23.8-inch Stainless P-Series Panel PC

Stainless IP69K with Waterproof Conduit Solutions

Accessories

Waterproof Conduit 1.5m

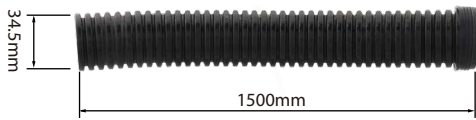

Elbow for connect the conduit



AC to DC power adapter

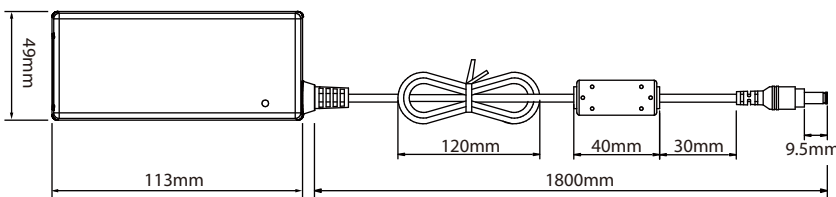

Open wire cable for phoenix connector(Default for 9~36V DC input sku)

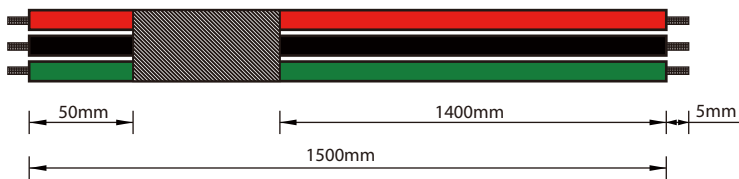

| Pin No. | Symbols | Color | | Pin No. | Symbols | Color |
|---------------|---------|-------|---|---------------|---------|-------|
| Open wire 5mm | | Red | ↔ | Open wire 5mm | | Red |
| Open wire 5mm | | Black | ↔ | Open wire 5mm | | Black |
| Open wire 5mm | | Green | ↔ | Open wire 5mm | | Green |

Yoke mount Stand kit (Optional)

