

FM12Q

12.1inch Android Car-mounted Computer with Qualcomm Snapdragon™ 660



Backplane
Systems
Technology

Backplane Systems
Technology Pty Ltd

TEL 02 9457 6400
sales@backplane.com.au
www.backplane.com.au

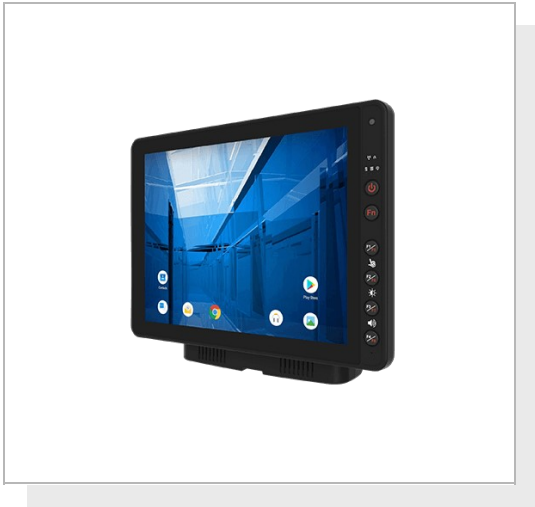

KEY FEATURES

- Qualcomm Snapdragon™ 660 octacore, 2.2 GHz CPU
- 12.1" 1024 x 768 Panel with PCAP Touch, Android car mounted computer
- Field replaceable front panel to reduce service costs
- IP65 waterproof and dustproof vehicle mounted computer
- Wide range -30°C to 50°C operating temperature



SPECIFICATIONS

Display			
Type	Projected Capacitive Multi Touch	Touch Mode	Support Hand, Stylus, Glove Mode
Resolution	1024x768	Size	12.1 inches
Contrast Ratio	1000:1	Panel Brightness	400 nits 800 nits(Optional)
View Angles	89,89,89,89		
System Specification			
Processor	Qualcomm® Snapdragon™ 660 (Octa-Core 2.2 GHz)	Memory	3GB
Storage	32GB	Operating System	Android 9.0
WLAN	Support	BT	Support
WWAN	4G/LTE (Optional)	GNSS	GPS/GLONASS
Sensors	G-Sensor, Temp. Sensor		
Camera			
Front Camera	2MP Camera		
Mechanical			
Dimension	Tablet: 307 x 225 x 41 mm Docking: 202 x 245 x 52 mm	Weight	Tablet 1.7 kg Docking 1.6 kg
Mounting	RAM Mount/ VESA Mount	Cooling System	Fanless Design
Docking Housing	Aluminum Alloy Housing		
IO Ports			
USB Port	1 x USB 3.0 Type C (OTG)(Tablet) 1 x DB9 Connector for 2 x USB 2.0 Port(Docking)	Serial Port	2 x COM Port(Docking)
SD Card Slot	1 x Micro SD Card Slot(Tablet)	SIM Card Slot	1 x Dual-Nano SIM Card Slot(Tablet)
Audio	2 x Speaker(Docking) 1 x CANBus or 1 x Audio(Docking)	LAN	1 x Gigabit LAN port(Docking)
Indicator	3 x LED Indicator (WLAN, UPS battery, Heater)		
Environment			
Operating Humidity	5% to 95% RH, Non-Condensing	Operating Temperature	-30°C to 50°C
Storage	-30°C to 60°C	Shock	MIL-STD-810H Method 516.8 Procedure I

Temperature			
Vibration	MIL-STD-810H Method 514.8 Procedure I	IP rating	IP65
Impact	Support EN62262 IK07 Rating	ESD	Compliant with EN 61000-4-2, Enhanced ESD to ±8kV Direct & ±15kV Air
Certification			
Certification	CE, FCC		
Control			
Button	1 x Power Button, 5 x Function Button (Programmable Function Key Configured by Winset)		
Power			
Battery	7.6V UPS Battery (2S1P) Minimum 30 minutes	Power Rating	Docking: 10V-60V with ignition control Tablet: 12V DC In
Security Function			
SOTI MobiControl	SOTI MobiControl Compliance		
Accessory			

Accessory	5M Power Cable with Fuse Kit 0.3M USB Cable 0.15M Power Converter Cable DC Jack Power Cable 84W Adapter with power cable Cable Clamp Kit Wi-Fi Antenna x 2 Quick Start Guide External Antenna Fixing Bracket Dock + Latch Locking Key Stylus Kit + Screw	Optional Accessory	1.8M RS232 Cable 0.3M Audio Cable 1.8M CAN BUS Cable 1.8M CAN BUS Open Wire Cable 2M IP65 LAN Cable GPS & LTE 2M Combo Antenna(VM240) GPS & LTE 5M Combo Antenna (VM9C) Magnetic Combo Antenna (VM10S) WWN Antenna HDMI Adapter
------------------	--	---------------------------	--

DIMENSIONS UNIT:MM

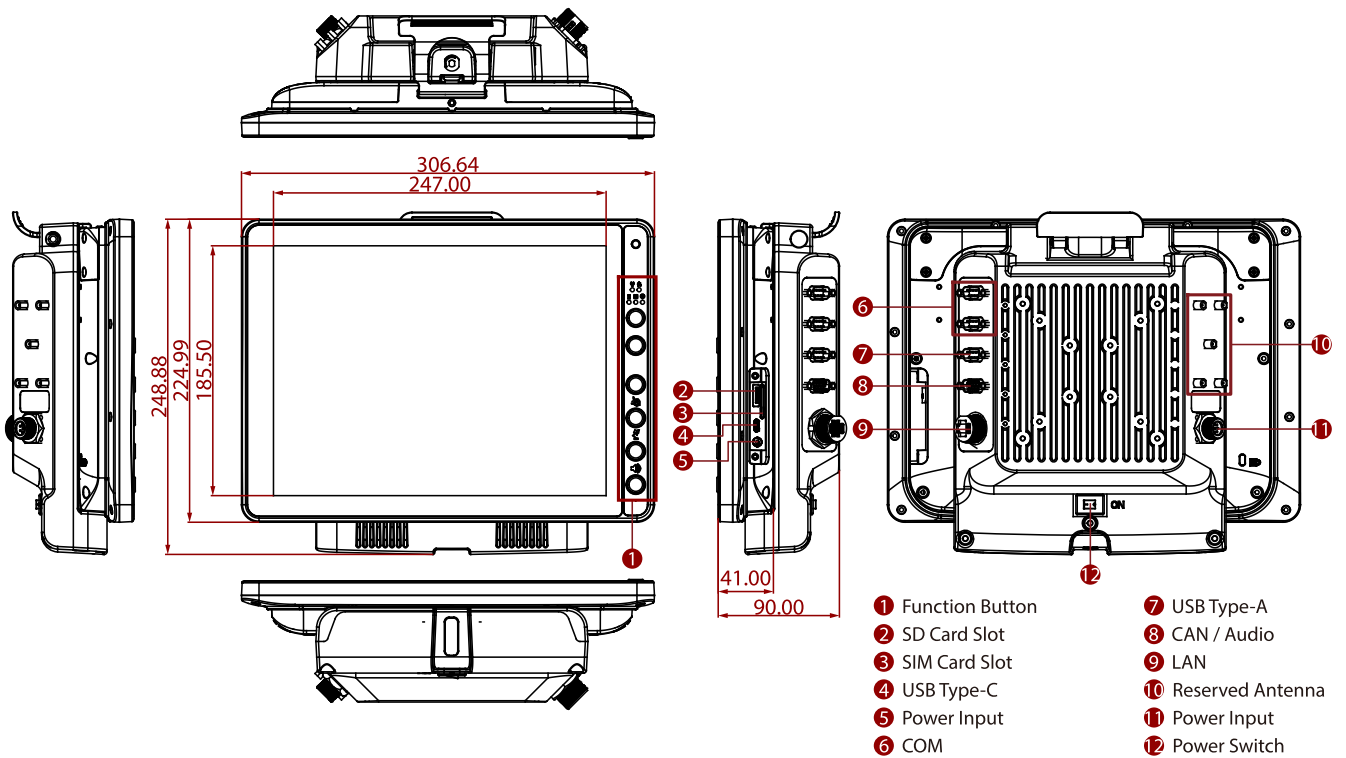

Backplane Systems
Technology Pty Ltd

Backplane
Systems
Technology

TEL 02 9457 6400
sales@backplane.com.au
www.backplane.com.au

NOTE

1. Total usable memory will be less dependent upon actual system configuration.
2. SOTI is available upon request.
3. Length measurements do not include protrusions. Weight varies with options.
4. Measured at dimming LCD brightness. Varies depending on the usage conditions, or when an external device is attached.
5. Accessories may vary depending on your configuration.
6. This is a simplified drawing and some components are not marked in detail.
7. The product shown in this datasheet is a standard model. For diagrams that contain customized or optional I/O, please contact the Winmate Sales Team for more information.

